

VKU Series

Eleksiz Vibrasyon Yüzey İşlem Makineleri

Vibratory Surface Finishing Machines without Separator



Ek Aksesuarlar

- Pnömatik Ses Kapağı
- Hız Kontrol
- Dozaj Pompası
- Manyetik Valf
- Elektrik Pano Standı
- Durulama Su Boru Sistemi
- Hareketli Ayırıcı Bölme

Additional Accesories:

- Pneumatic Sound Lid
- Frequency Control
- Dossage Pump
- Magnetic Valve
- Control Panel Base
- Rinsing Pipe
- Paddle Wheel

VKU serisi vibrasyon makineleri her türlü metal ve metal dışı malzemelerden mamül parçaların yüzey işlemlerinde kullanılır. Bu seri makinalar malzemeleri ayırıcı eleğe sahip değildir. Genellikle büyük hacimli ve hassas yüzeyli parçalar için kullanılır.

VKU series machines can be used for surface finishing of metal and nonmetal work pieces. These type of machines do not have a separation screen. Generally used for big volume and delicate surfaced work pieces.



Bowl Inner Design
Kazan İç Görünüm



Media Unload Gate
Taş Tahliye Kapağı

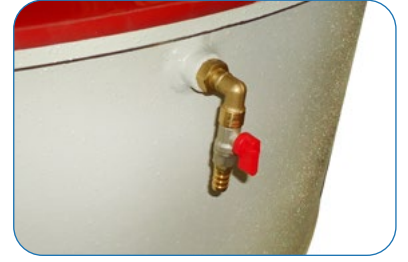

Water and Compound Inlet Valve
Su ve Kimyasal Giriş Aparatı



Dirty Water Discharge Valve
Pis Su Tahliye Vanası



Machine Springs
Makine Yayları



Electric Control Panel
Elektrik Panosu

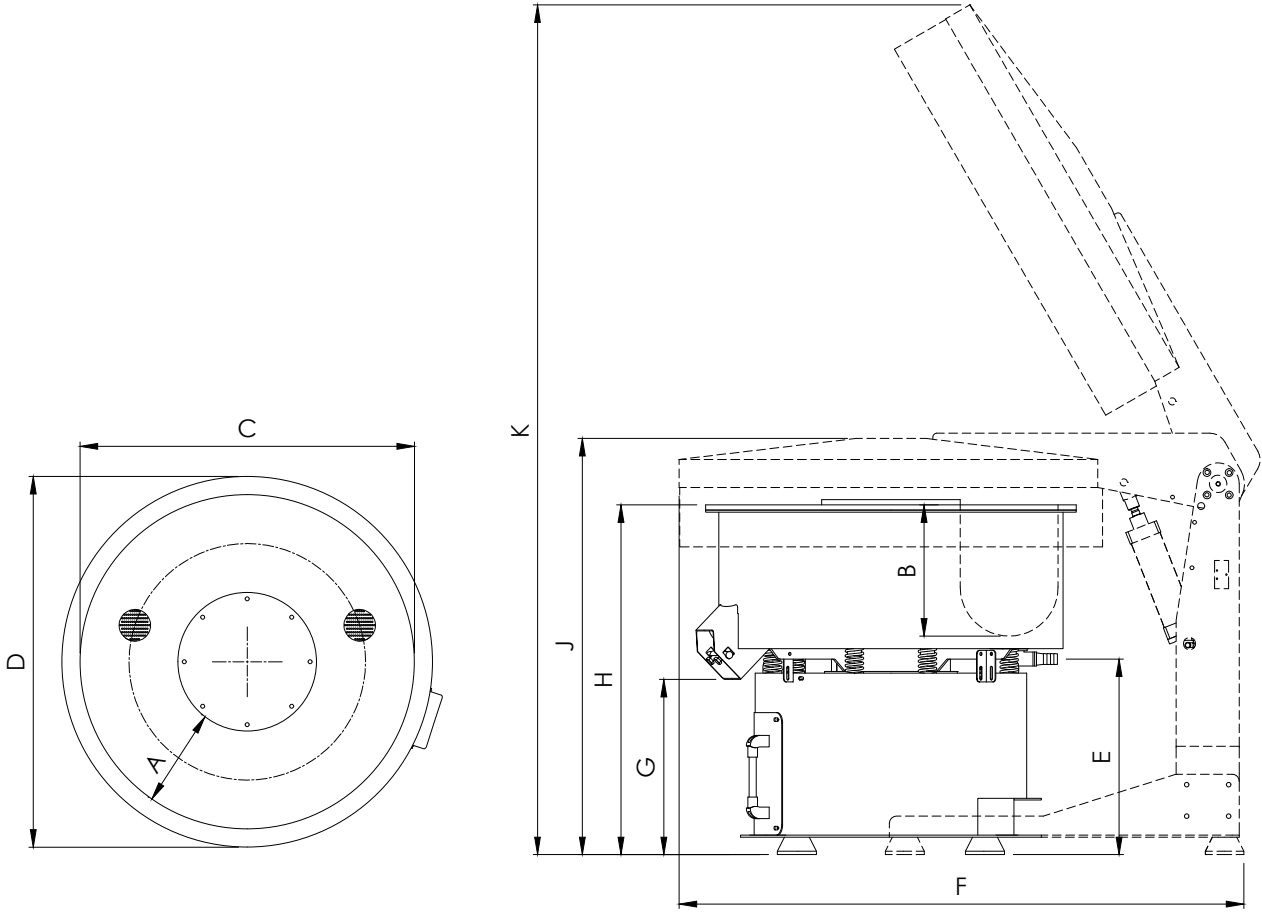

Teknik Ölçüler Technical Dimensions

TİP / TYPE		VKU 15	VKU 30	VKU 50	VKU 100	VKU 200	VKU 400	VKU 600	VKU 800	VKU 1000	VKU 1200	VKU 1700
Brüt Hacim Gross Volume	Lt	17	32	51	102	210	408	610	820	1010	1230	1718
PU Kalınlığı PU Thickness	mm	10-20	10-20	15-25	15-25	15-25	15-25	15-25	15-25	15-25	15-25	20-30
Motor Gücü Engine Power	Kw	380/50	380 / 50	380 / 50	380 / 50	380 / 50	380 / 50	380 / 50	380 / 50	380 / 50	380 / 50	380/50
Gerilim Voltage	V/Hz	1500	1500	1500	1500	1500	1500	1500	1500	1500	1500	1500
Çalışma Devri Operating Speed	rpm	0,35	0.35	0.5	0.7	1.1	1.9	2.5	5.5	7	7	11
Ağırlık Weight	Kg	100	120	140	220	350	600	820	1050	1220	1380	2150
A	mm	125	140	210	250	280	360	400	460	490	550	630
B	mm	150	200	215	300	375	460	520	575	630	650	680
C	mm	400	510	610	730	950	1200	1410	1560	1630	1750	2020
D	mm	460	590	700	820	1060	1310	1530	1680	1780	1900	2180
E	mm	350	350	450	500	550	550	500	500	500	500	600
F	mm	--	--	--	1220	1620	1900	2100	2320	2400	2550	2900
G	mm	--	--	--	500	525	525	450	450	450	450	600
H	mm	720	800	900	900	1050	1100	1100	1250	1250	1250	1400
J	mm	--	--	--	1100	1230	1300	1300	1450	1450	1450	1660
K	mm	--	--	--	2000	2600	2900	3050	3300	3400	3500	3940