

Eleksiz Vibrasyon Yüzey İşlem Makineleri

Vibratory Surface Finishing Machines without Separator



Ek Aksesuarlar

- Pnömatik Ses Kapağı
- Hız Kontrol
- Dozaj Pompası
- Manyetik Valf
- Elektrik Pano Standı
- Durulama Su Boru Sistemi
- Hareketli Ayrıcı Bölme

Additional Accesories:

- Pneumatic Sound Lid
- Frequency Control
- Dossage Pump
- Magnetic Valve
- Control Panel Base
- Rinsing Pipe
- Paddle Wheel

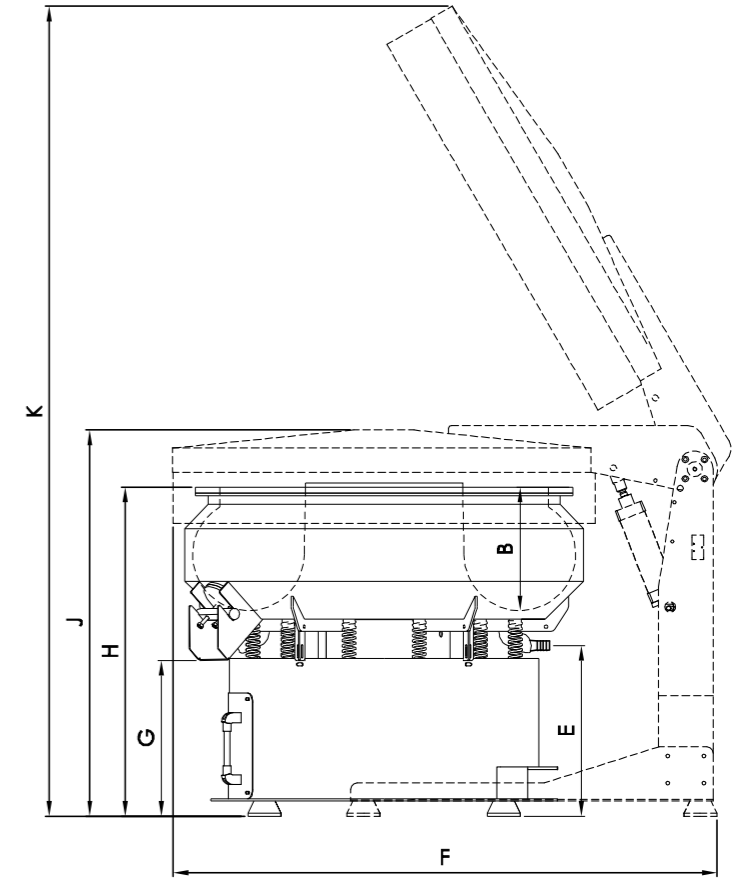
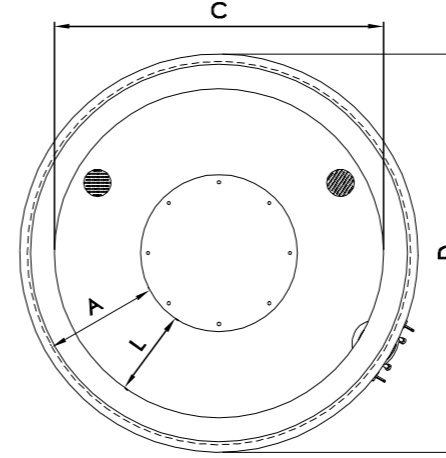

VKO serisi vibrasyon makineleri her türlü metal ve metal dışı malzemelerden mamül parçaların yüzey işlemlerinde kullanılır. Bu seri makineler malzemeleri ayırıcı eleğe sahip değildir. Genellikle büyük hacimli ve hassas yüzeyli parçalar için kullanılır.

VKO series machines can be used for surface finishing of metal and nonmetal work pieces. These type of machines do not have a separation screen. Generally used for big volume and delicate surfaced work pieces.



Paddle Wheel
Ayrı Bölme Çarkı



Electric Control Panel
Elektrik Panosu



Media Unload Gate
Taş Tahliye Kapağı



Dirty Water Discharge Valve
Pis Su Tahliye Vanası



Pneumatic Sound Lid
Pnömatik Ses Kapak

Teknik Ölçüler Technical Dimensions

TİP / TYPE		VKO 75	VKO 150	VKO 250	VKO 350	VKO 500	VKO 650	VKO 1000	VKO 1300
Brüt Hacim Gross Volume	Lt	76	150	275	348	505	690	1075	1335
PU Kalınlığı PU Thickness	mm	15-25	15-25	15-25	15-25	15-25	15-25	15-25	15-25
Motor Gücü Engine Power	Kw	0,7	1,1	1,9	1,9	2,5	5	7	11
Gerilim Voltage	V/Hz	380/50	380/50	380/50	380/50	380/50	380/50	380/50	380/50
Çalışma Devri Operating Speed	rpm	1500	1500	1500	1500	1500	1500	1500	1500
Ağırlık Weight	Kg	160	320	550	610	680	1300	1800	2010
A	mm	230	240	320	370	420	470	530	580
B	mm	270	340	400	420	470	530	600	625
C	mm	600	800	970	1100	1150	1300	1600	1700
D	mm	740	1000	1220	1320	1440	1620	1920	2150
E	mm	500	500	525	525	550	550	650	650
F	mm	1220	1470	1670	1790	1860	2100	2400	2520
G	mm	470	470	500	500	500	500	600	600
H	mm	850	900	1050	1100	1150	1200	1400	1450
J	mm	1050	1100	1250	1300	1350	1400	1600	1650
K	mm	2030	2220	2500	2680	2820	3050	3520	3680
L	mm	200	200	230	280	310	330	400	460

Tüm ölçüler milimetredir.
All dimensions are millimeters.

Vibromak makinelerin renk ve teknik değerlerinin değişim hakkını saklı tutar.
Vibromak reserves the right for changing the colors and technical values of the machines.